



CHEFMATE FULL TOUCH CMFE6HUWICPSX

four mixte électrique full touch



SPÉCIFICATIONS TECHNIQUES:

Capacité niveaux	6
Typologie bac	GN 1/1 - 60x40cm
Injection vapeur	direct
Puissance électrique (kW)	9,5
Dimensions extérieure - LxPxH (cm)	89x79,5x72

SPÉCIFICATIONS SUPPLÉMENTAIRES:

Chambre de cuisson - LxPxH (cm)	63x44x49
Espacement des grilles (mm)	70
Energie (N)	400V 3N 50Hz
Poids (kg)	120

La nouvelle interface avec écran tactile rend l'utilisation et la programmation de Chefmate Full Touch extrêmement rapide et simple, en offrant au chef la possibilité d'un travail quotidien plus convivial. Tous les combis sont Full optional avec HU Contrôle d'humidité / W Lavage automatique / U port usb / ICP Sonde interne multipoints inclus.

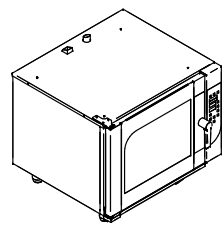
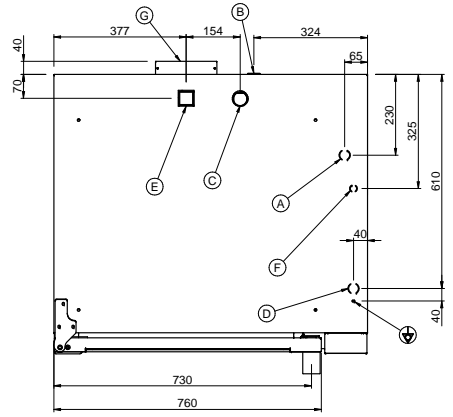
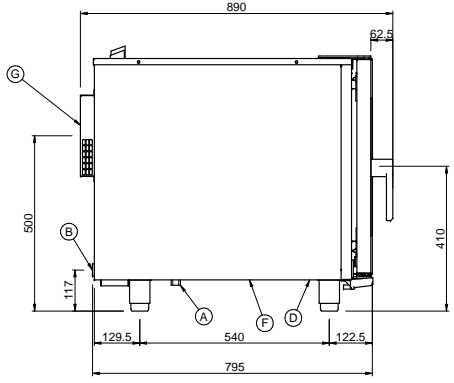
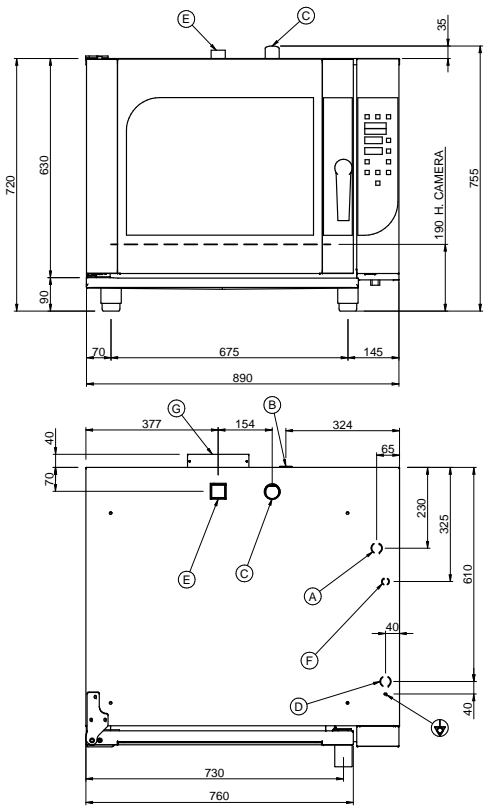

- A: INGRESSO ACQUA ADDOLCITA 3/4" G
- B: SCARICO ACQUA 1" G
- C: TUBO SFIATO (VAPORE) D 40mm
- D: INGRESSO CAVO DI ALIMENTAZIONE ELETTRICA
- E: TUBO ASPIRAZIONE ARIA
- F: INGRESSO TUBO DETERGENTE
- G: VENTOLA RAFFREDDAMENTO POSTERIORE

REV.	MODIFICATION	DATE	MODIFIED BY

MATERIAL	-	Thk	-	Formal feedback	-	Dimensions are in mm		SURFACE TOLERANCES	3.2√
FINISHED OR TREATMENT	-	Thk Treat. μ	-	Color	-	GENERAL TOLERANCES	VEDI I.C. 82	GENERAL GEOMETRIC TOLERANCES	ISO 2768
USED FOR	CHEFMATE CME6	N.Wt.	0,000 kg	Scale	1/10	Date	16/05/14	Approved by	
		TITLE: SCHEMA INSTALLAZIONE CHEFMATE CME6 - CMFE6 - CYE6							
BRESCELLO (RE) - ITALY		Raw Code	-	Deep Drawing Code	-	Drawn by	G. FANETTI		
		Implanted Code	-	Finished Code	-	Dwg n°	SCHEMA INST CM6		

La ditta si riserva, a termini di legge, la proprietà di questo disegno con divieto di riprodurlo o di renderlo pubblico a Terza senza la Sua autorizzazione.
 The Company reserves the right by law, the property of this drawing with no copy or to make it public to any third party without your permission.